

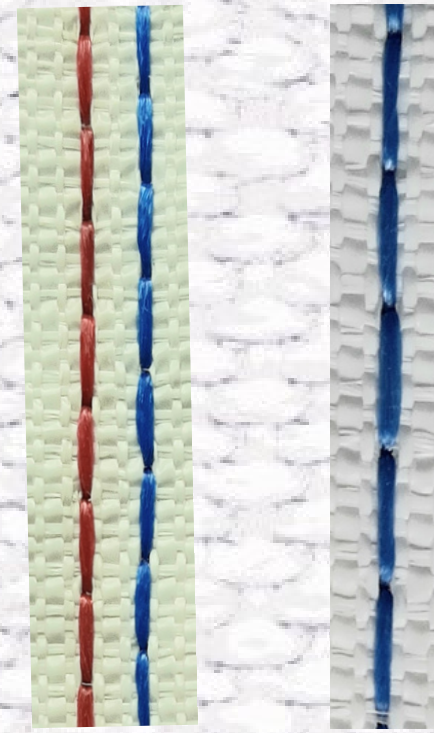

GS 2500, GS 2500-2, GS 2500-H, GS 2500-2H

**CHAIN STITCH SEWING MACHINE
SPRING OR PNEUMATIC / SINGLE OR DOUBLE NEEDLE
DOUBLE TRANSPORTED SEWING MACHINE**

- SPECIAL DESIGN FOR BIG BAG (FIBC) PRODUCERS
- USED FOR SEWING MEDIUM DUTY BIG BAGS
- FILLER CORDS ARE STANDART FROM ABOVE AND BELOW

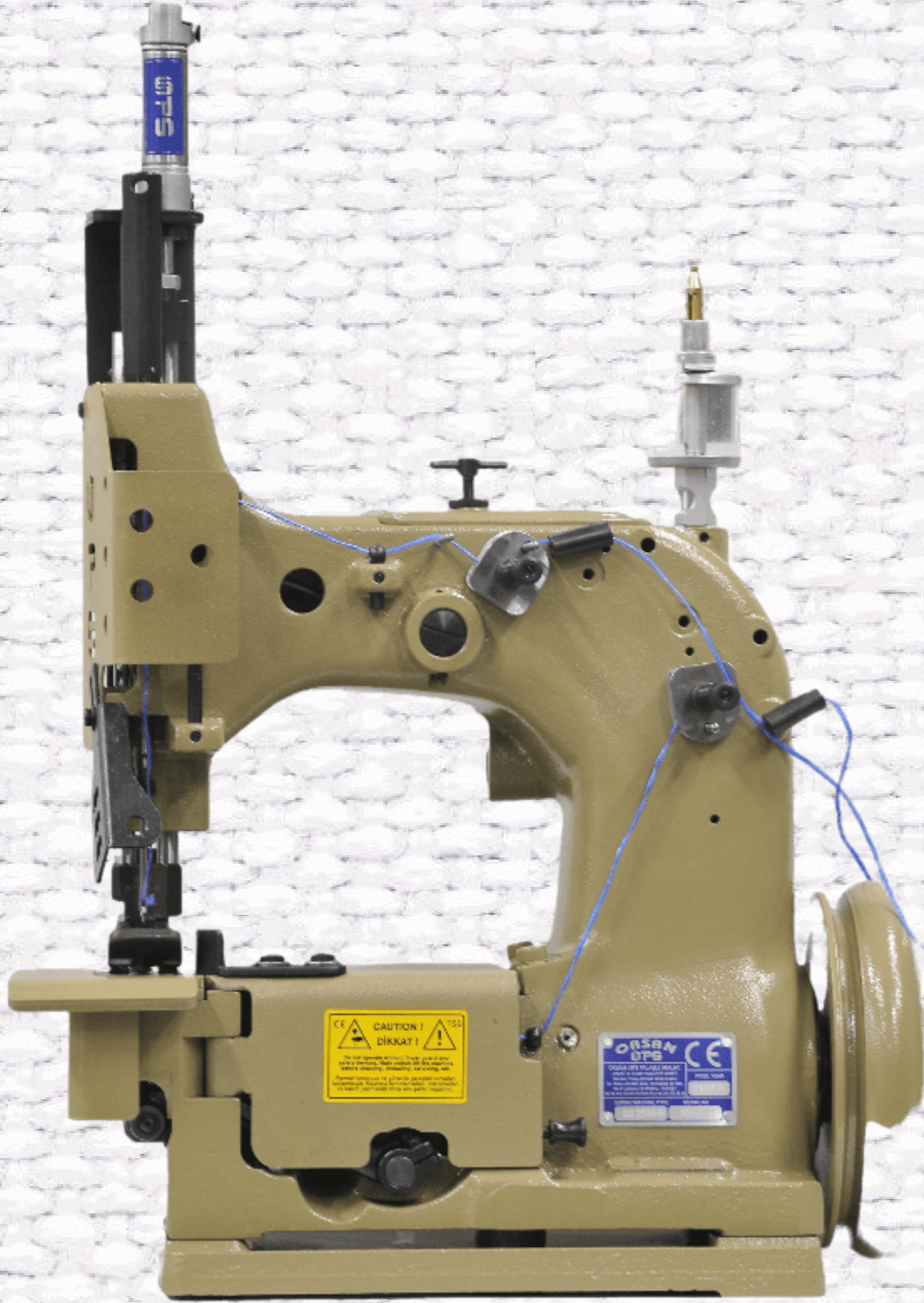

2200 rpm

GS 2500 & gs 2500-2 Series Classic Spring System

GS 2500H & GS 2500-2H Pneumatic Presser Foot System

ORSAN OPS TALAŞLI İMALAT SAN. ve TİC.KOLL. ŞTİ
Ferhatpaşa SB Mah. Ali Rıza Efendi Cad. No:27, Çatalca, İstanbul
TEL: +90 212 472 08 78/79/80 FAX: +90 212 472 08 81

www.orsanops.com

info@orsanops.com





3500, 3500-2, 3500-H, 3500-2H

CHAIN STITCH SEWING MACHINE

SPRING OR PNEUMATIC / SINGLE OR DOUBLE NEEDLE DOUBLE TRANSPORT SEWING MACHINE

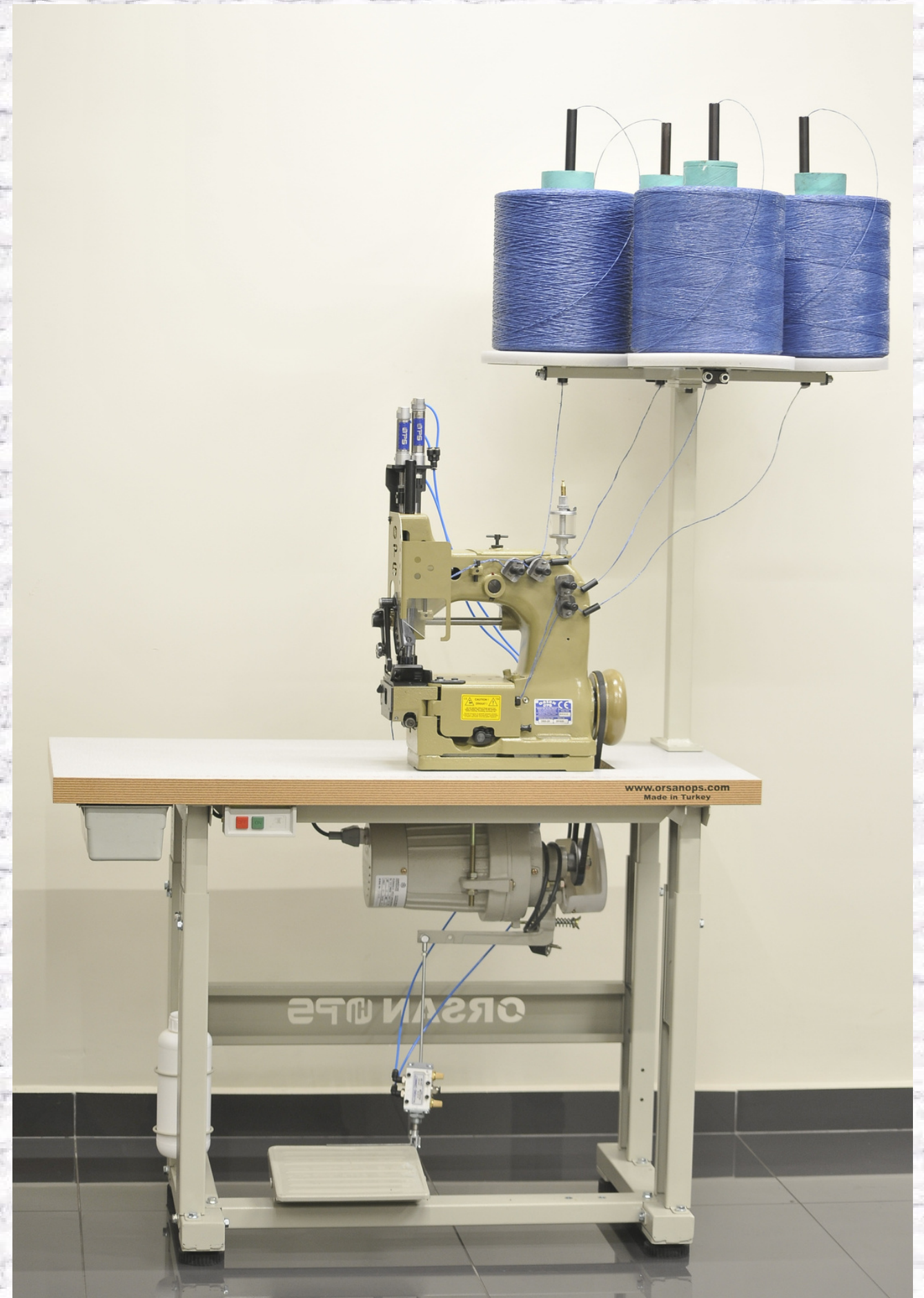
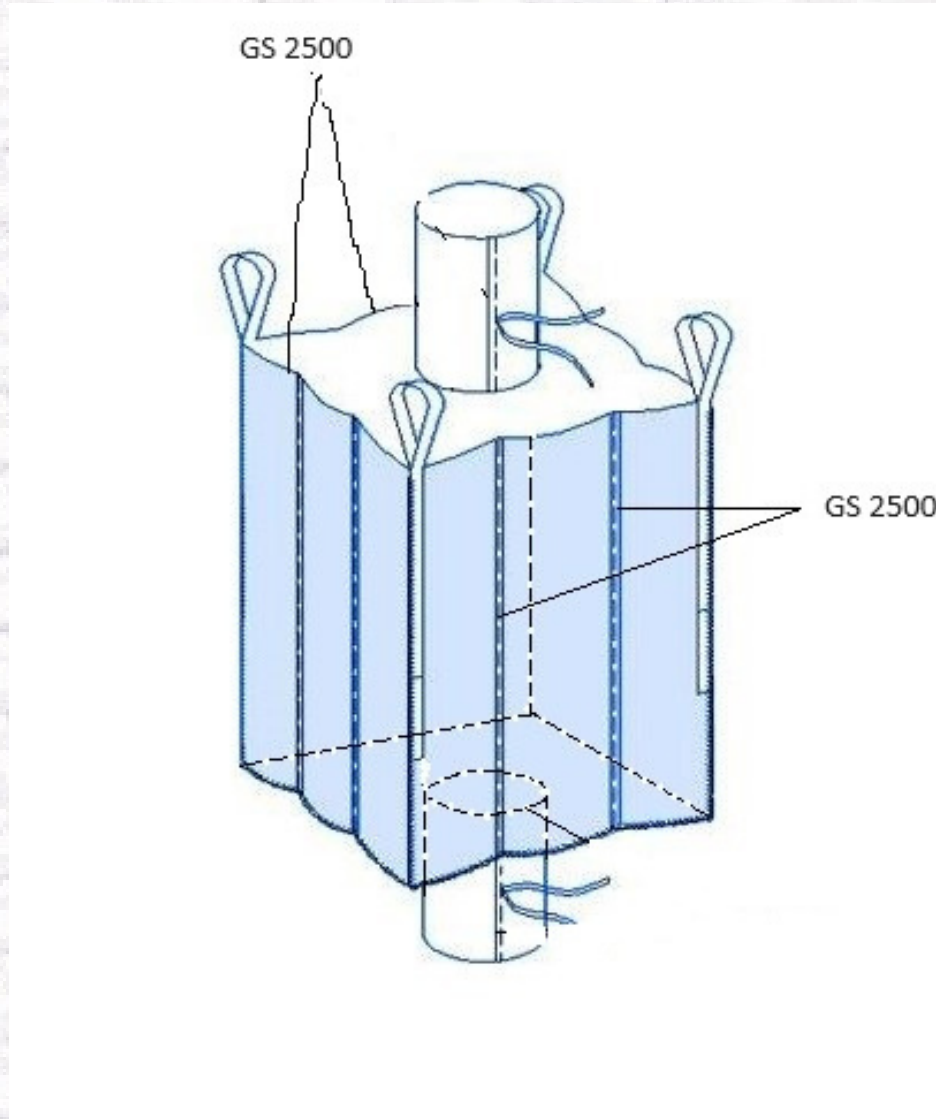

- This machine is developed only for Big, Bag industry.
- Used for sewing the top panel of a big bag to main body and for sewing of baffle panels.
- Designed to create higher efficiency thanks to the higher rpm power (RPM 2200)
- The problem is removed that needle touches the looper which occurs at similar machines.
- Filler cords are standard from above and below.
- Heat cutting can be installed if required.
- Low spare part consumption.

MACHINE MODEL	GS 2500	GS 2500-2	GS 2500-H	GS 2500-2H
NEEDLE TYPE	UY 9848 GS 300/120	UY 9848 GS 300/120	UY 9848 GS 300/120	UY 9848 GS 300/120
NUMBER OF NEEDLES	1	2	1	2
YARN TYPE	Monofilament	Monofilament	Monofilament	Monofilament
NUMBER OF YARNS	2	4	2	4
YARN DENIER RANGE	2500 – 5000	2500 – 5000	2500 – 5000	2500 – 5000
DISTANCE BETWEEN NEEDLES	N/A	7mm	N/A	7mm
STITCH TYPE	Single Chain	Double Chain	Single Chain	Double Chain
STITCH LENGTH RANGE	7-13 mm	7-13 mm	7-13 mm	7-13 mm
TRANSPORT SYSTEM	Single (Bottom)	Single (Bottom)	Single (Bottom)	Single (Bottom)
PRESSING SYSTEM	Spring	Spring	Pneumatic	Pneumatic
PRESSING FOOT TYPE	Shock Absorber	Shock Absorber	Shock Absorber	Shock Absorber
MAXIMUM RPM	2200	2200	2200	2200

ORSAN OPS TALAŞLI İMALAT SAN. ve TİC.KOLL. ŞTİ

Ferhatpaşa SB Mah. Ali Rıza Efendi Cad. No:27, Çatalca, İstanbul

TEL: +90 212 472 08 78/79/80 FAX: +90 212 472 08 81

www.orsanops.com info@orsanops.com